

Logic Masters 2013 Qualification round

Solving time: 2:30 hours

The puzzles were created by the following authors:

Sebastian Matschke (4, 6, 7, 9, 12, 17, 19, 20), Martin Merker (3, 5, 8, 10, 13, 14, 18), Philipp Weiß (1, 2, 11, 15, 16)

1. Minesweeper

5 Punkte

Place an unknown number of mines into the grid. The numbers indicate how many mines can be found in horizontally, vertically or diagonally adjacent cells. Each cell can contain at most one mine, and numbered cells must not contain a mine at all.

1									
	5		3		2	2	1	1	2
	4				3		3		2
	5		4		4		6		2
	4				4				4
	3	1	2		2		5		4
1									1

Answer key: For each row, enter the total number of mines.

2. Skyscrapers with parks

5 Punkte

Place digits from 0 to 4 into the grid, so that each digit appears exactly once in each row and column; exactly one cell in each row and column remains empty. A 0 represents a park, the digits greater than 0 represent skyscrapers of different heights; the numbers outside the grid indicate how many skyscrapers can be seen in the respective row or column from the respective direction. Smaller skyscrapers are hidden behind higher ones.

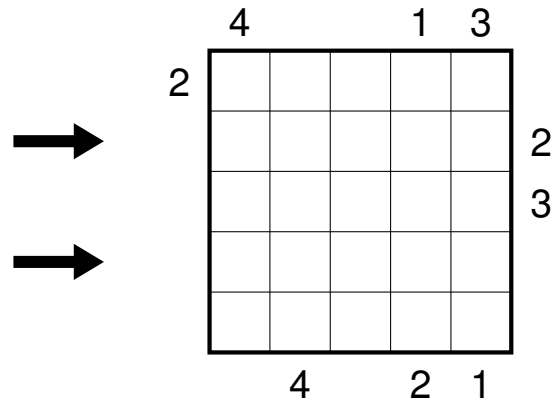

Answer key: For each row marked by an arrow, enter the digits from left to right.

3. Tapa

10 Punkte

Shade some empty cells black to create a single connected wall. Numbers in a cell indicate the length of consecutive shaded blocks in the neighboring cells. If there is more than one number in a cell, then there must be at least one white (unshaded) cell between the black cell groups. Cells with numbers cannot be shaded, and the shaded cells cannot form a 2x2 square anywhere in the grid.

3			1 2	4			3 3		
	1 2			2		1 3			
			4						
								1 1	
2					1 1				
			2 2						
	3						3		

Answer key: For each row, enter the total number of black cells.

4. Dissecion

10 Punkte

Divide the grid along the dotted lines into any number of copies of the given pieces. The pieces may be rotated, but not reflected. Black cells can not be part of any piece.

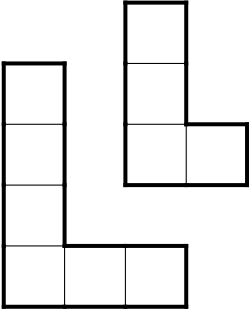
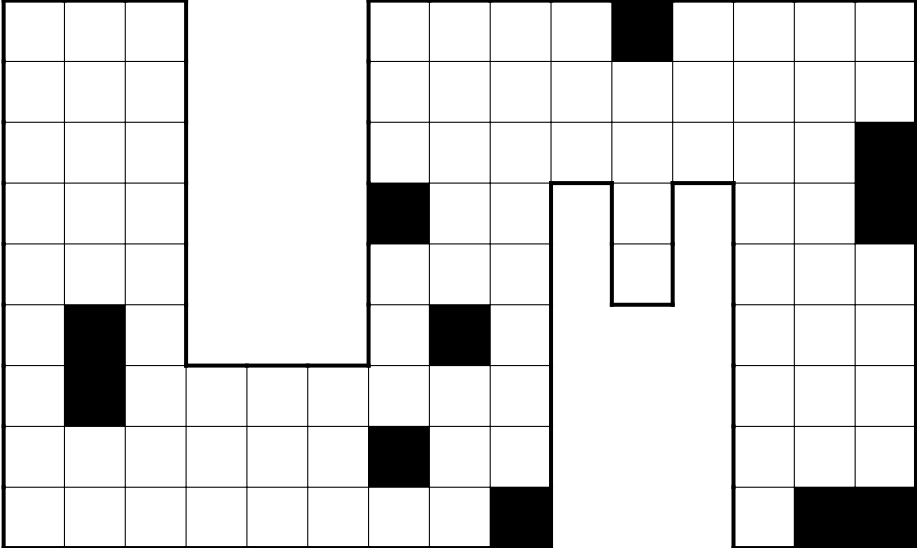

Answer key: For each column, enter the number of pieces that appear in this column.

5. Star Battle

15 Punkte

Place stars into the grid, so that each row, each column and each outlined region contains exactly two stars. The stars have the size of one cell and must not touch each other, not even diagonally.

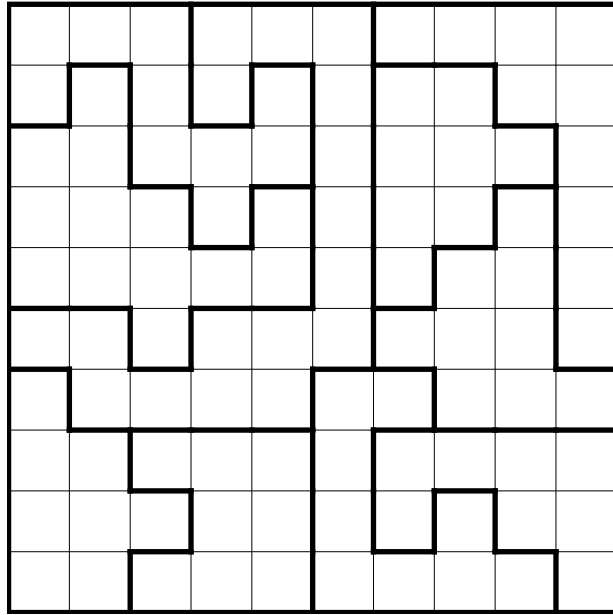

Answer key: For each row, enter the number of cells between the two stars (not counting the cells containing the stars).

6. Outside Prime Sudoku

15 Punkte

Place digits from 0 to 4 into the grid, so that each digit appears exactly once in each row, column and outlined region. The letter 'P' outside the grid indicates that the number form by the first two digits in the respective row or column is a prime number. The outer digit represents the tens, the inner digit the units. All 'P's are given, in other words, if there is no 'P', the respective two-digit number is not prime. (Prime numbers are positive integers with exactly two divisors: 2, 3, 5, 7, 11, 13, 17, 19, 23, 29, 31, 37, 41, 43, 47, ...)

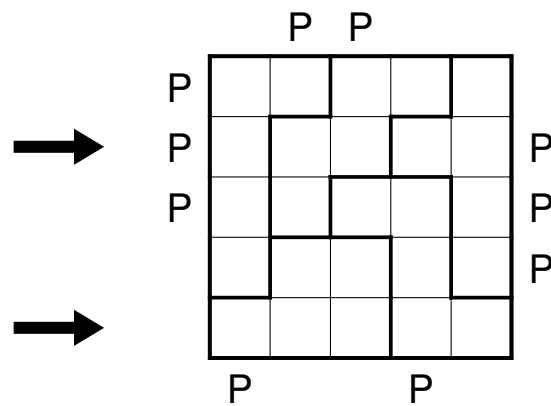

Answer key: For each row marked by an arrow, enter the digits from left to right.

7. Kropki

15 Punkte

Place digits from 1 to 6 into the grid, so that each digit appears exactly once in each row and column. A white dot between two adjacent cells indicates that these cells hold consecutive numbers, and a black dot indicates that one number is exactly half of the other. If there is no dot between two adjacent cells, then neither property holds. A dot between the numbers 1 and 2 may be black or white, and not necessarily consistent throughout the puzzle.

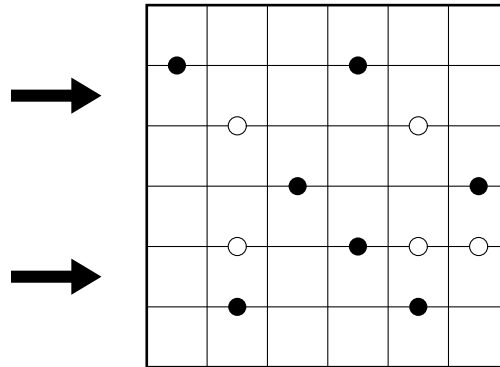

Answer key: For each row marked by an arrow, enter the digits from left to right.

8. Broken Railroads

15 Punkte

For each number from 1 to 10, shade exactly one of the two copies. Draw a closed loop into the grid, that runs only horizontally and vertically and passes through each cell except the shaded cells. The loop must cross itself in the marked spots, and only there. The 'stations', indicated by digits, must be passed through in the order -1-2-3-4-5-6-7-8-9-10-1-, and the loop must not change direction in any station.

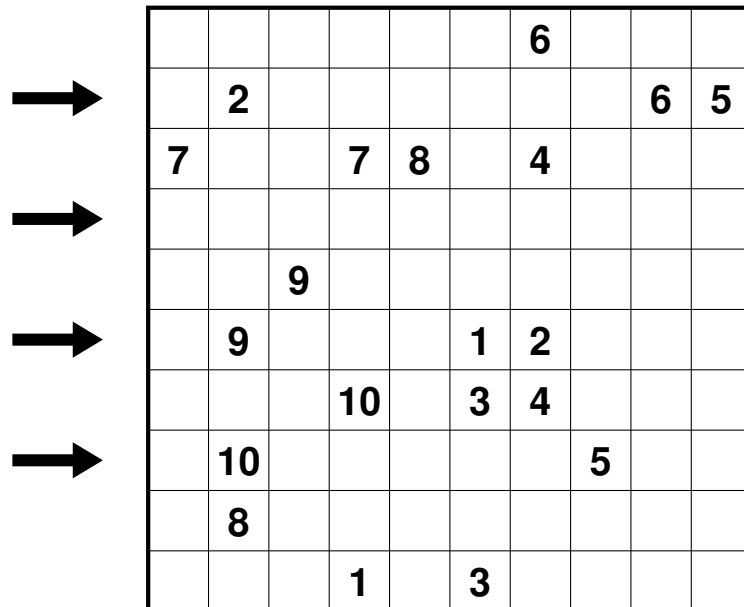

Answer key: For each row marked by an arrow, enter the length of horizontal sections of the loop in that row from left to right.

9. 4 Snakes

20 Punkte

Draw four snakes into the grid, each snake starting in the center and ending in a different corner. A snake must not touch itself, not even diagonally. Different snakes can use adjacent cells, however the starting point is the only cell they share. All snakes must have the same length (which is not given). Numbers outside the grid indicate the number of cells used by the snakes in the respective row or column.

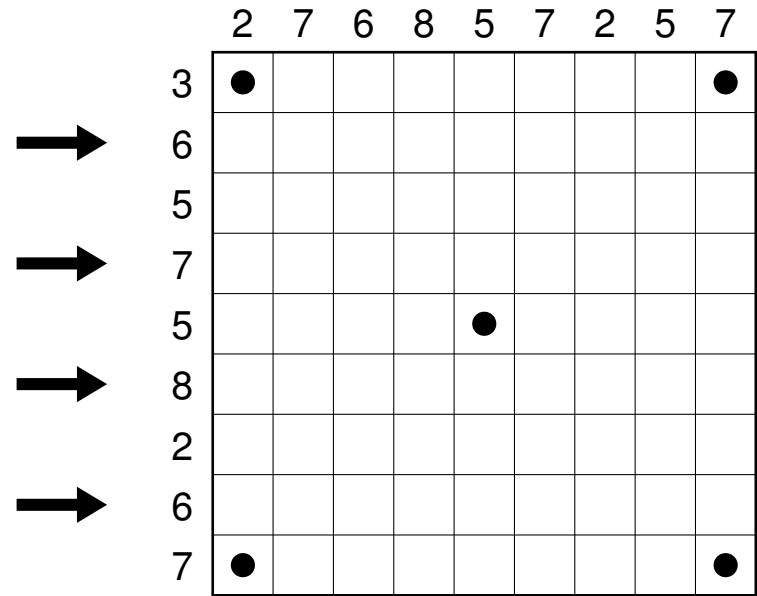

Answer key: For each row marked by an arrow, enter the length of horizontal sections of the loop in that row from left to right.

10. Hitori - Smashed Sums

20 Punkte

Hitori (left): Shade some cells, so that in the unshaded cells each digit appears at most once in each row or column. Shaded cells must not be horizontally or vertically adjacent, and all white cells are connected (the black cells must not divide the grid into two or more parts).

Smashed Sums (right): Shade some cells and place digits from 1 to 4 into the grid (1 to 2 in the example), so that each row and column contains each digit exactly once as well as two shaded cells. The numbers outside the grid indicate the sum of the digits between the two shaded cells in the respective row or column.

Furthermore, no cell can have the same content in both grids, neither the same (unshaded) digit nor being shaded in both grids.

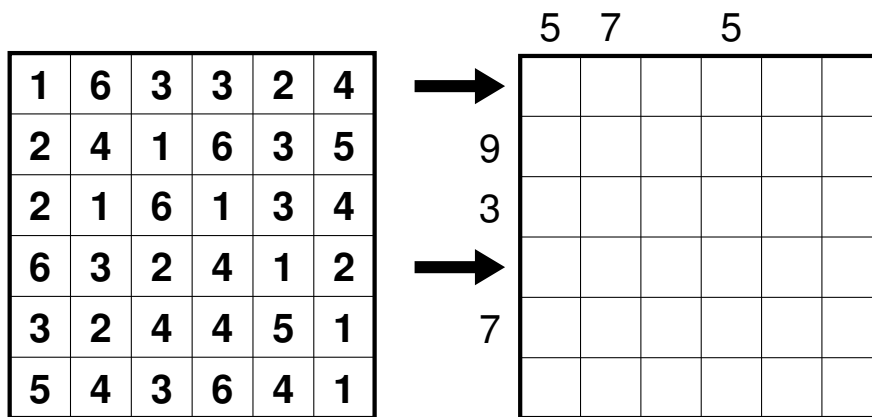

Answer key: First, enter the total numbers of shaded cells for each row in the Hitori. Second, for each row in the smashed sums marked by an arrow, enter the digits from left to right.

11. Slither Link

25 Punkte

Draw a single continuous loop by connecting neighboring dots along the dotted lines. The numbers indicate how many edges of a cell are used for the loop. The loop may not touch or cross itself, and it does not need to touch all of the dots.

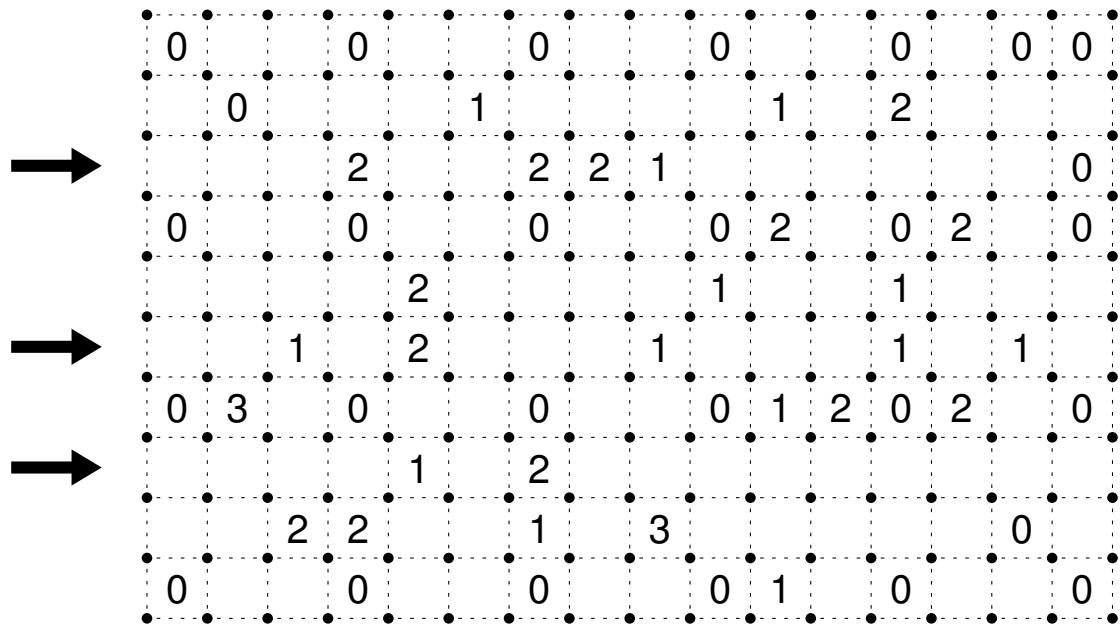

Answer key: For each row marked by an arrow, for each sequence of connected cells inside the loop, enter the number of cells.

12. Hex-Masyu

25 Punkte

Draw a path system, connecting the centers of adjacent cells, passing through all cells with symbols. The path may pass straight through a cell or make a 120° angle, however 60° angles are not allowed. The path may branch out (any number of times); that means, from one cell lines are drawn to three adjacent cells, making three 120° angles (again, 60° angles are not allowed). All parts of the path must be connected, and there must not be any open ends.

The symbols have the following meaning:

- white circle: The path must pass straight through, and in the next cell in at least one direction it must make a turn or branch out.
- black circle: The path must make a 120° angle (not a branch), and it must go straight through the next cell in both directions.
- branching symbol (Y): The path must branch out, in the directions indicated by the symbol.
- asterisk: The path must branch out, in either of the two possibilities.

It is possible, that not all branching points are given.

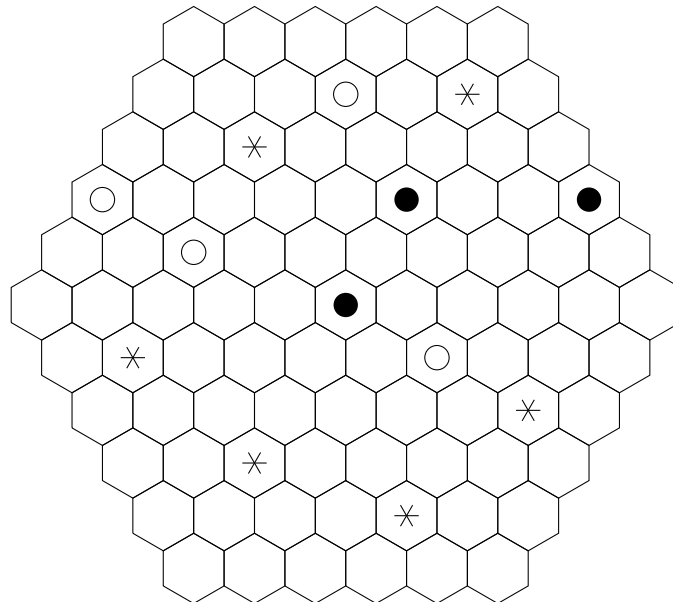

Answer key: For each row, enter the number of empty cells.

13. Skyscrapers Fillomino

25 Punkte

Divide the grid into several regions and fill in a number into each square. Within each region, all numbers must be the same and be equal to the number of squares of that region. Regions of same size may touch each other only diagonally. Furthermore, consider each region as a skyscraper of the respective height. Numbers outside the grid indicate how many skyscrapers can be seen in the respective row or column from the respective direction. Smaller skyscrapers are hidden behind higher ones, or behind skyscrapers of the same height. It is possible for skyscrapers of the same height to appear in the same row or column.

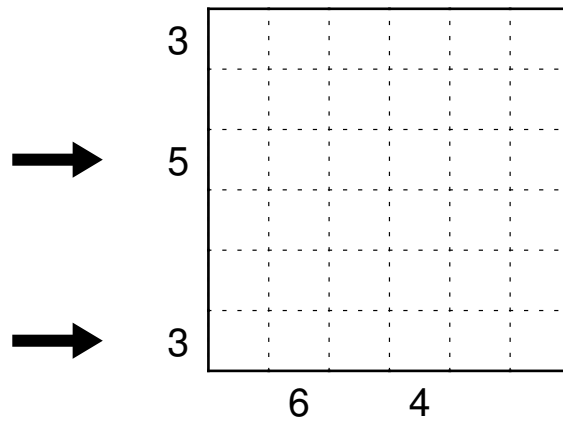

Answer key: For each row marked by an arrow, enter the digits from left to right.

14. Kuromasu

25 Punkte

Shade some empty cells, so that no two shaded cells are horizontally or vertically adjacent and all white cells are connected (the black cells must not divide the grid into two or more parts). The numbers indicate how many cells are visible in all four directions, including the numbered cell itself.

						7		
4			3					4
							5	
	2				4			
				6				
							3	
								9
		7						
								7
3						3		

Answer key: For each row, enter the number of shaded cells.

15. Mirrors

25 Punkte

There are persons (capitel letters) and objects (lower case letters) in the grid. Each person is looking in one of four directions, (north, east, south, west) and can see an object with a corresponding letter. Each object is seen by exactly one person, and no person is seeing another person. Find out in which direction each person is looking, and place some diagonal mirrors in the grid; cells containing mirrors must not touch each other, not even diagonally (even if the mirrors wouldn't be touching). At a mirror, the line of sight is reflected in a 90° angle. Lines of sight can cross each other, and mirrors can be used from both sides. The bold lines are non-transparent walls.

	1	2	3	4	5	6	7	8
C				c				
A							C	
A			c				b	b
			B	d				
					a			
	B	D	d				D	a

Answer key: For each row, enter the position of all mirrors in that row.

16. 4x4x4-Sudoku

30 Punkte

A cube consisting of 4x4x4 cells is given. The grids represent the four layers of this cube. Place letters from A to P into the cells, so that each of the 12 possible layers consisting of 16 cells contains each letter exactly once. This includes the 4 layers shown as well as another 8 layers using the third dimension; these 8 layers consist of the same row or column in each separate grid. (The example uses a cube of 3x3x3 cells with letters from A to I.)

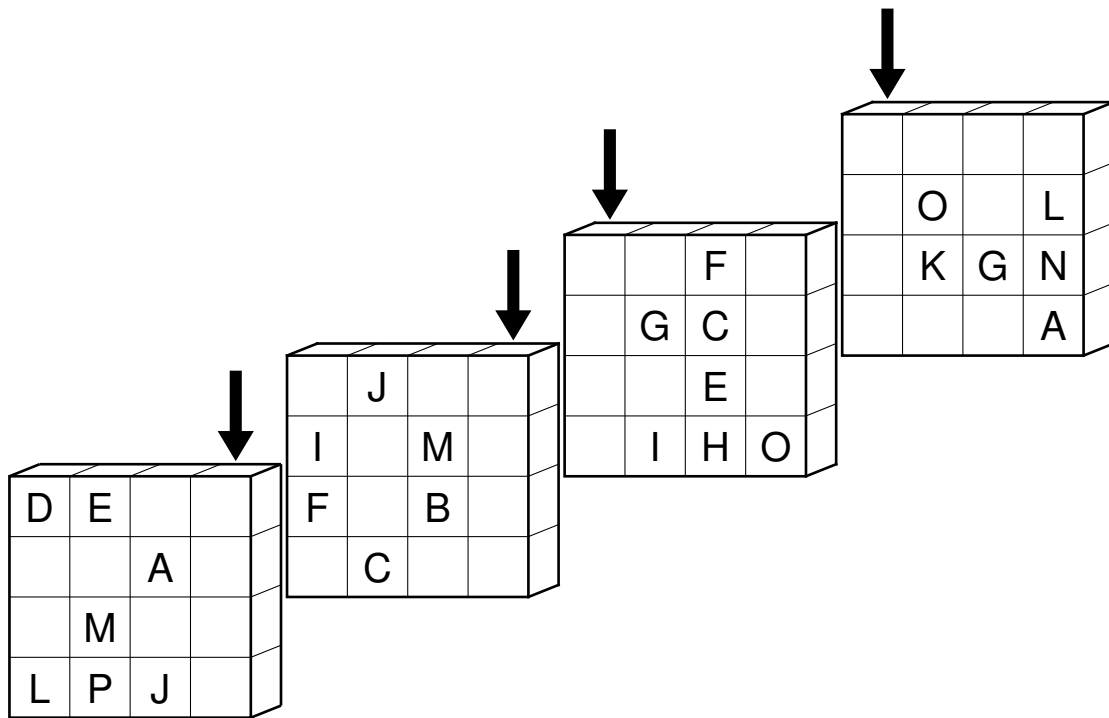

Answer key: For each column marked by an arrow, enter the letters from top to bottom.

17. Battleships

30 Punkte

Place the given fleet into the grid, so that ships do not touch each other, not even diagonally. Ships can be placed horizontally or vertically. The numbers outside the grid indicate the number of ship segments in the respective row or column.

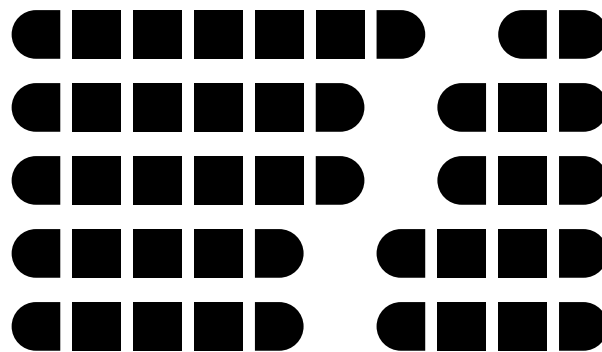
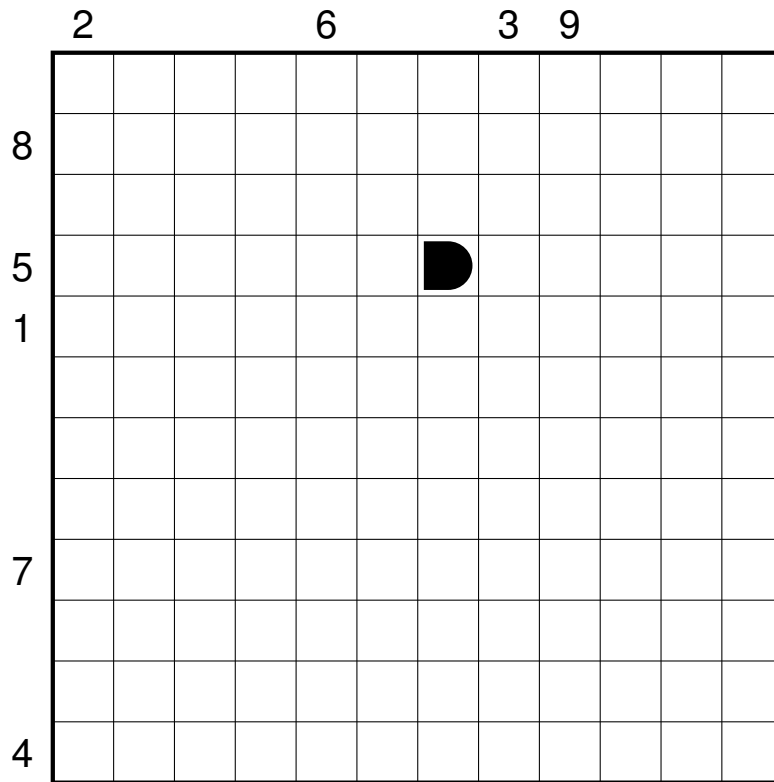

Answer key: First, for each row the number of ship segments from top to bottom, second for each column the number of segments from left to right.

18. Non-Consecutive Kakuro

45 Punkte

Place digits from 1 to 9 into the white cells. The numbers in grey cells indicate the sum of digits in the corresponding "word"(continuous horizontal or vertical white cells). Within each word, no digit can repeat. Horizontally or vertically adjacent cells must not be consecutive.

	12			14	7	11	24		36	19
4			13					12		
6			31					35		
21						29				
	16									
	14			11	5	7	29			
		32								
			6							
	11					18				
	13					23				

Answer key: For each row marked by an arrow, enter the digits from left to right. Ignore grey cells (empty cells and cells that contain the given sums).

19. Capsules

50 Punkte

Place digits from 1 to 5 into the grid, so that each outlined region contains each digit exactly once. Same digits must not touch each other, not even diagonally.

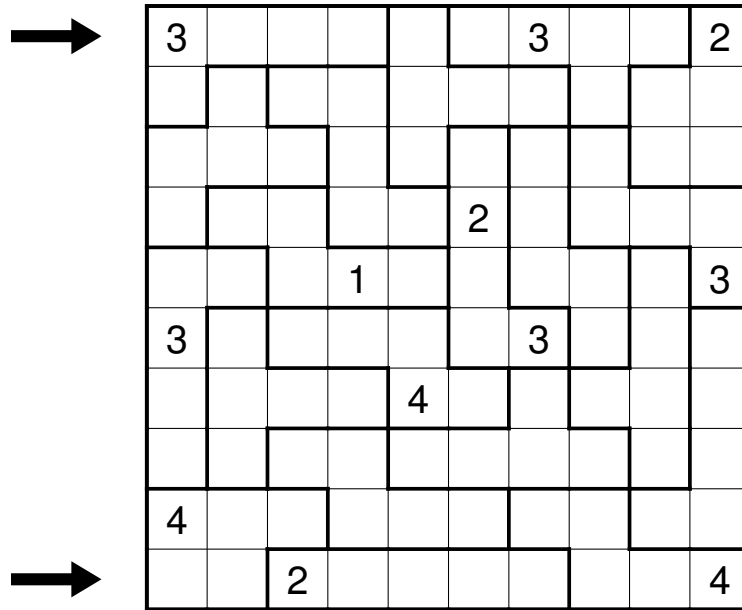

Answer key: For each row marked by an arrow, enter the digits from left to right.

