

Instruction booklet for the qualifying test of Logic Masters 2008

On Saturday, April 26, the official test file will be available for download. Make sure you have read and understood the rules of the contest.

Welcome to the qualification round for the Logic Masters 2008!

We hope you enjoy the competition, whether you compete seriously or just for fun.

The test will consist of 20 puzzles, some of them extremely difficult. We believe nobody will be able to solve all of them in time. Solve those puzzles you can solve and skip the others; if you have time left, you can always come back to them.

The points for the puzzles have been assigned according to their difficulty. You may use these information to decide, which puzzles to try first. However, keep in mind your estimation of a puzzles difficulty may differ from ours.

We wish you good luck, enjoy the puzzles!

Last minute changes:

If there are any changes or clarifications, they will be announced in our forum at <http://forum.logic-masters.de/viewforum.php?f=7>

Remember:

- Wrong answers will yield a penalty of 5 points. Be careful when entering your answer keys.
- Enter the answer keys you already have, to avoid time trouble at the end of the test. Remember, late answers will yield a penalty of 10 points per minute.
- You are solely responsible for sending your answers in time.
- You must solve the qualification puzzles without outside help. Computer programs, Sudoku solvers or similar are not allowed.

Answer key:

Please try to obey the following guidelines when entering your answer keys:

- If you have to enter several rows, separate them by comma, not by spaces only. In each row, enter your solution from left to right.
- If not specified differently, enter your solution from top to bottom.
- If several letters or digits from one row have to be entered, form a word („ABC“ instead of „A,B,C“).

Instructions

The following instructions come directly from the test file; only the diagrams have been removed. Instead of them, small examples are shown. These examples can not be found in the test file. You should read and understand the instructions and examples before the test.

1 Skyscrapers

10 points

Place a skyscraper of height 1 to 5 into each square, such that each row and column contains each digit exactly once. The numbers outside the diagram indicate, how many skyscrapers are visible from that direction; lower skyscrapers are concealed behind higher ones.

Example (using digits 1-4):

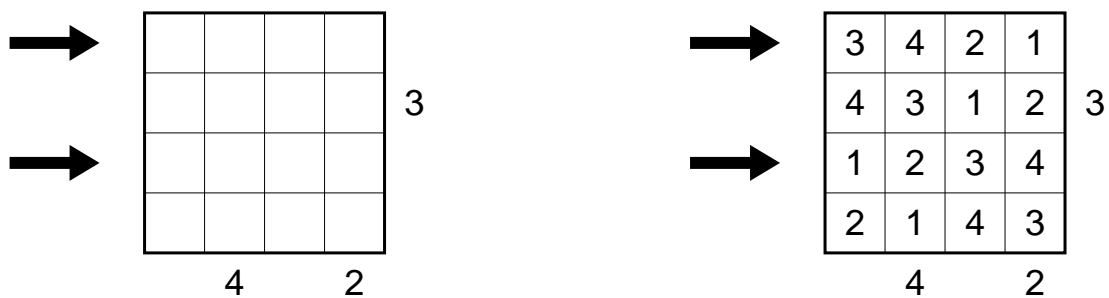

Answer key: Enter the digits in the marked rows from left to right.

For the example, the answer key would be: 3421, 1234

2 Sightseeing Tour

10 points

Find a route through the city, that starts in any one of the places of interest (represented by digits), finishes in another and passes through all other places of interest.

No street section or crossing may be used more than once. The streets marked with arrows are one-way streets and may be passed only in the marked direction. The arrows are valid only till the next crossing or place of interest.

Example:



Answer key: Enter the digits in the order you pass through them.

For the example, the answer key would be: 1324

3 Rekuto

15 points

Divide the diagram along the grid lines into rectangles, such that each rectangle contains exactly one number which indicates the sum of width and height of the rectangle.

Example:

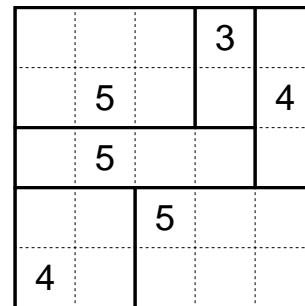
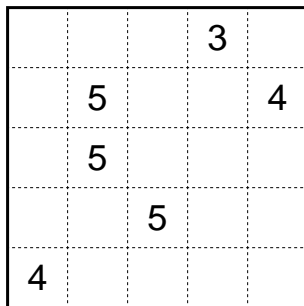

Answer key: Enter from top to bottom for each row, how many rectangles are located (partly) in that row.

For the example, the answer key would be: 3, 3, 2, 2, 2

4 Kropki

20 Punkte

Enter digits from 1 to 9 into the diagram, such that each row and column contains each digit exactly once.

A black circle between two horizontally or vertically adjacent digit indicates, that one of these digits is exactly twice the value of the other; a white circle indicates, that the difference between these digits is exactly 1. If there is no circle between two adjacent digits, none of these two properties may hold.

Example (using digits 1-6):

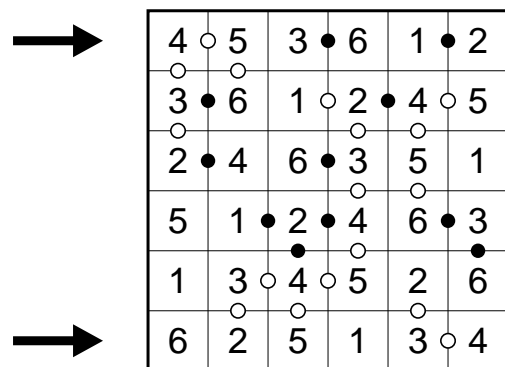
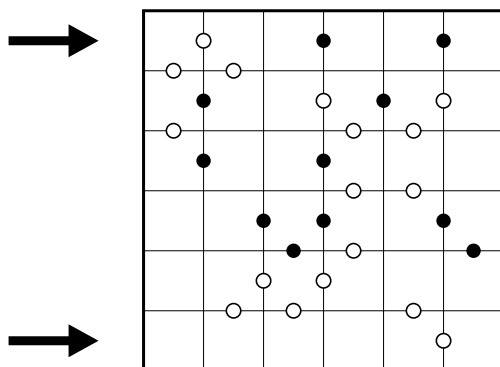

Answer key: Enter the digits in the marked rows from left to right.

For the example, the answer key would be: 453612, 625134

5 Star Battle

20 points

Place stars into the diagram, such that each row, each column and each black-edged part contains exactly two stars. The stars have the size of one square and may not touch each other, not even diagonally.

Example:

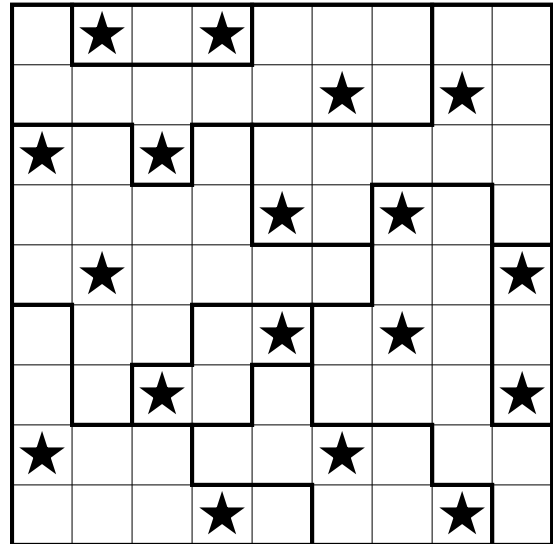
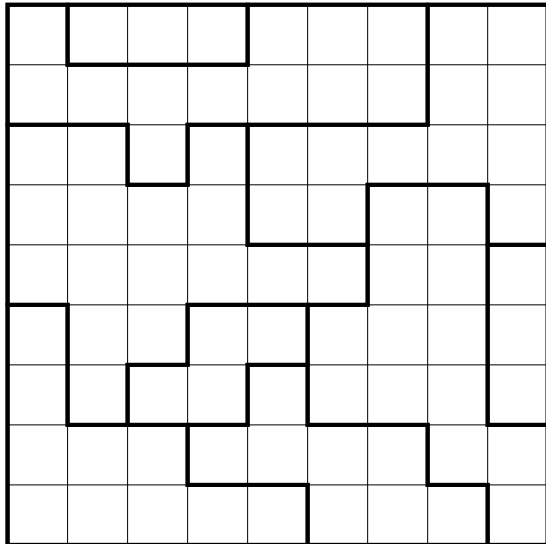

Answer key: From top to bottom, enter for each row the number of empty squares between the two stars (do not count the squares containing stars itself).

For the example, the answer key would be: 1, 1, 1, 1, 6, 1, 5, 4, 3

6 Easy as ABC

20 points

Place letters A, B, C in the diagram, such that each row and column contains each letter exactly one; four squares remain empty in each row and column. The letters outside the diagram indicate, which letter comes first in the respective row or column.

Example (one empty square in each row and column):

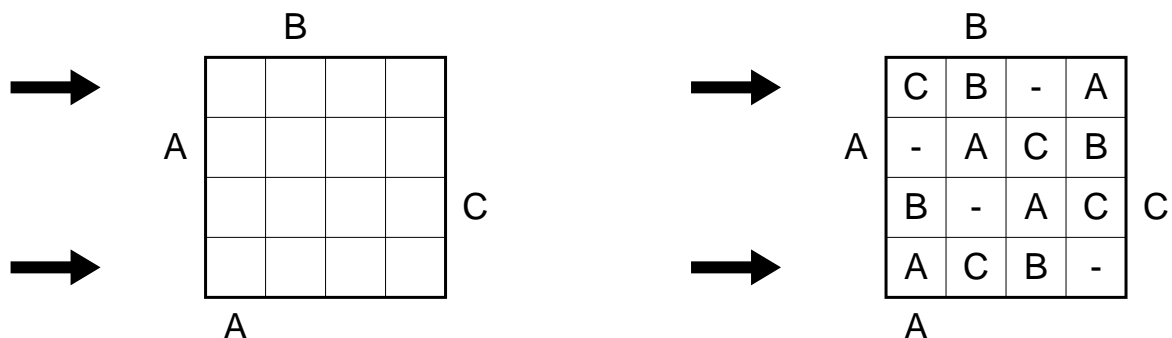

Answer key: Enter the letters in the marked rows from left to right. Use '-' for empty squares.

For the example, the answer key would be: CB-A, ACB-

7 Slither Link

25 points

Draw a single continuous loop by connecting neighboring dots along the dotted lines. The numbers indicate how many edges of a square are used for the loop. The loop may not touch or cross itself, and it doesn't need to touch all of the dots.

Example:

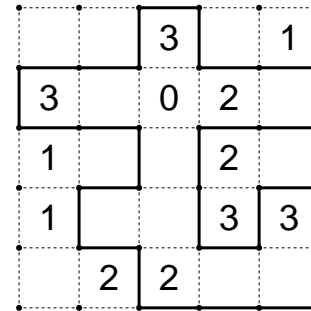
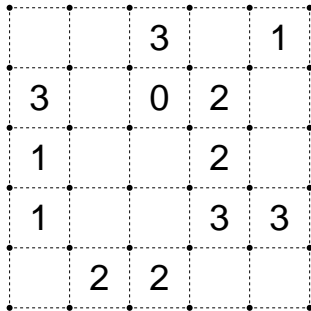

Answer key: From top to bottom, enter for each row the given numbers that are inside the loop. Write '-' for any row where no digit is inside the loop.

For the example, the answer key would be: 3, 302, -, 3, 2

8 Kakuro

25 points

Enter digits from 1 to 9 into the white squares. The numbers in white squares indicate the sum of digits in the corresponding „word“. In each word, no digit may repeat.

Example:

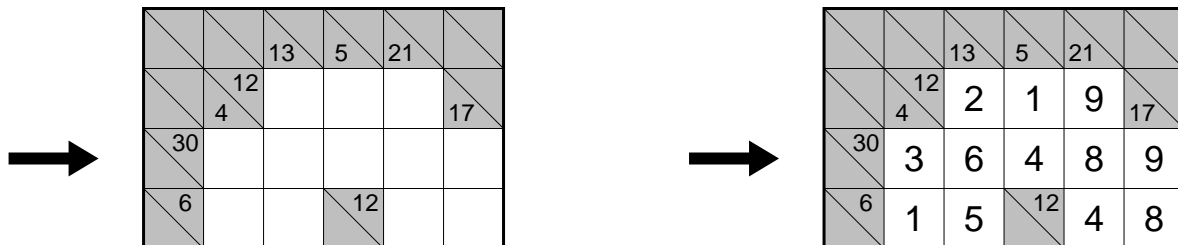

Answer key: Enter the digits in the marked row from left to right.

For the example, the answer key would be: 36489

9 Balancing Act

25 points

Place weights from 1 to 8 in the marked spots, such that the system is in perfect equilibrium. Each weight must be used exactly once.

Example (using weights 1-4):

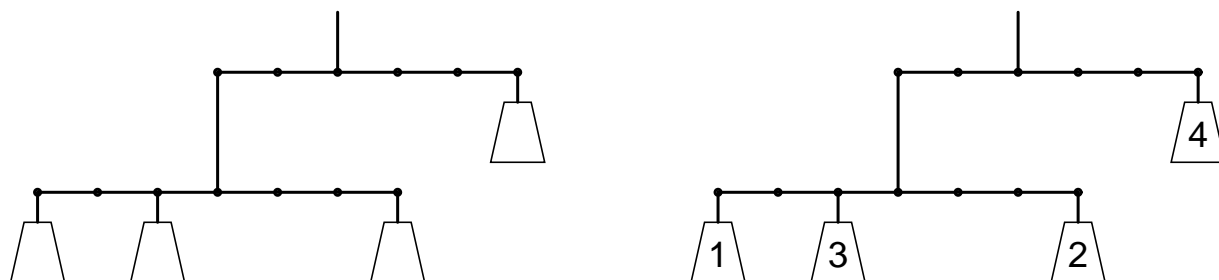

Answer key: Enter from left to right the five weights in the top row, followed by the three weights in the bottom row.

For the example, the answer key would be: 4, 132

10 Spiral

25 Punkte

Enter digits from 1 to 3 into the diagram, such that each row and column contains each digit exactly once. If you pass along the spiral from the outside to the center, the sequence 1, 2, 3 must always repeat, beginning with digit 1.

Example:

		2		
	3			1
			2	

	1	2	3	
2	3			1
		3	1	2
1			2	3
3	2	1		

Answer key: Pass along the spiral from the outside to the center. Enter the number of empty squares between each digit 1 and their subsequent digit 2 (do not count the digits itself).

For the example, the answer key would be: 0, 0, 0, 1, 0

11 Railroads

30 points

Draw a closed loop into the diagram, which runs only horizontally and vertically and passes through every square. The loop must cross itself at the marked spots, and only there. The „stations“, indicated by digits, must be passed through in the order 1-2-3-4-5-6-7-8-1-, and the loop may not take a turn in any station.

For solving purposes, ignore the letters at the crossings.

Example (using stations 1-4):

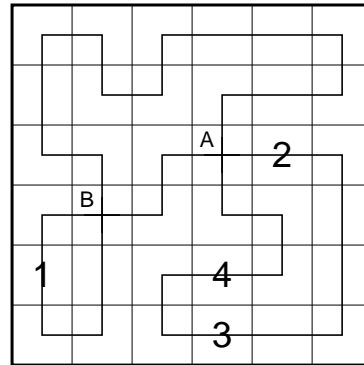
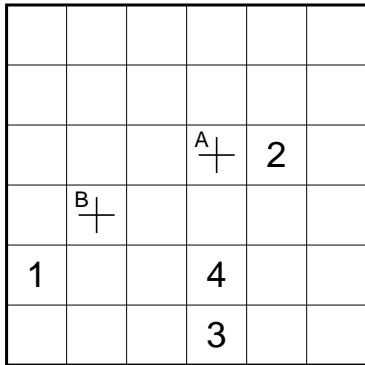

Answer key: Start at station 1 and go towards station 2, until you arrive at station 1 again. Enter the letters assigned to the crossings in the order you pass through them.

For the example, the answer key would be: BAAB

12 Squares

30 points

Remove three points, such that the remaining points do not contain four points which form the vertices of a square. The edges of these squares need not be along the grid lines.

For solving purposes, ignore the letters and digits outside the grid.

Example (remove two points instead of three):

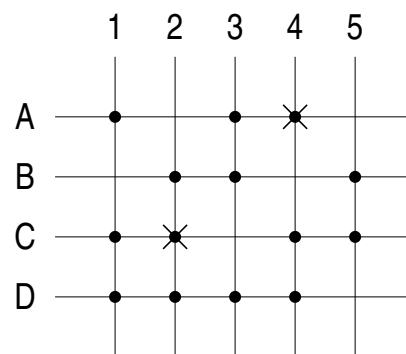
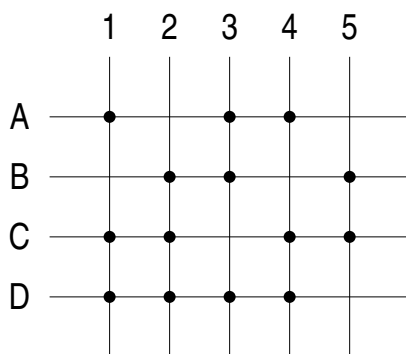

Answer key: Enter the coordinates of the three points.

For the example, the answer key would be: A4, C2

13 Japanese Sums

30 points

Blacken some squares in the diagram, then enter digits from 1 to 7 in the remaining squares, such that each row or column contains each digit at most once.

The numbers outside the diagram indicate the sums of all blocks of consecutive (no black square between them) digits. Single digits are given as well.

Example (using digits 1-4):

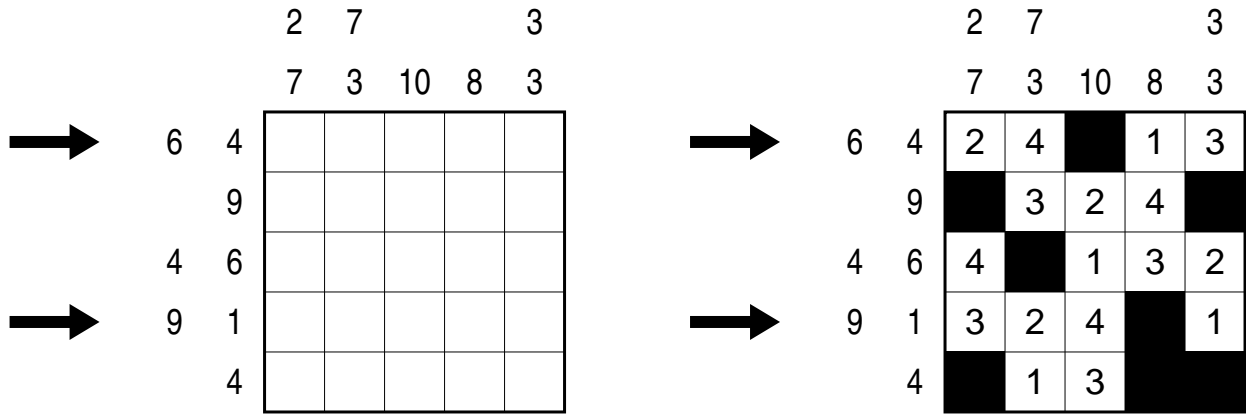

Answer key: Enter the digits in the marked rows from left to right. Use '-' for black squares.

For the example, the answer key would be: 24-13, 324-1

14 Tetrominoes

35 points

Place the seven tetrominoes into the diagram, such that they do not touch each other, not even diagonally. The numbers left and above the grid indicate, how many squares in that row or column are occupied; the numbers right and below the grid indicate, how many tetrominoes use at least one square of the respective row or column.

The tetrominoes may be rotated, but not reflected.

Example (using three tetrominoes only):

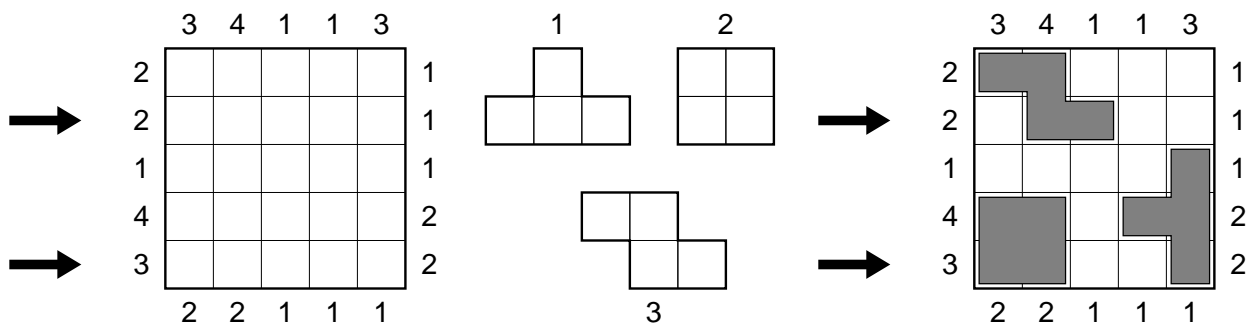

Answer key: Each tetromino has been assigned a number from 1 to 7. For the marked rows, enter from left to right for each square, which tetromino occupies that square; use '-' for empty squares.

For the example, the answer key would be: -33- -, 22- -1

15 Word Path

35 points

Place letters into the circles, such that all given words can be read in the diagram: Each pair of consecutive letters must be connected by a straight line.

Two letters, that are not consecutive in any word, must not be connected.

Example:

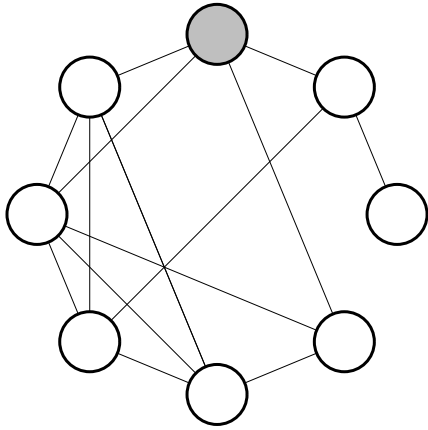

ARTIST
EINSAM
INTERN

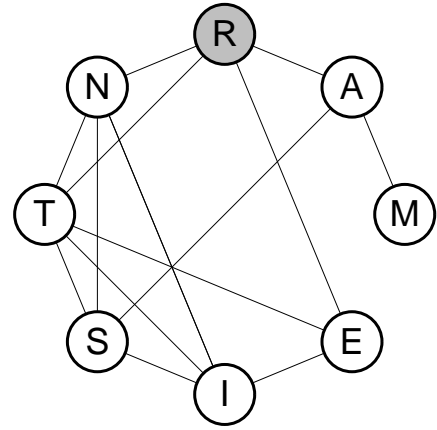

Answer key: Enter the letters clockwise, start with the grey circle.

For the example, the answer key would be: RAMEISTN

16 Pentomino Path

40 points

Place the twelve pentominoes into the diagram, such that they form a closed loop which doesn't touch itself, not even diagonally. The numbers outside the diagram indicate how many squares in each row and column are used for the path.

For some pentominoes, not all five squares can be used for the path. In total, there are six such unused squares; these must be the grey colored squares. Beware: the numbers outside the diagram do not count the grey squares, and the grey squares may touch the path in any way.

All pentominoes may be rotated and reflected.

For solving purposes, ignore the letters in the pentominoes.

Example (using five pentominoes only):

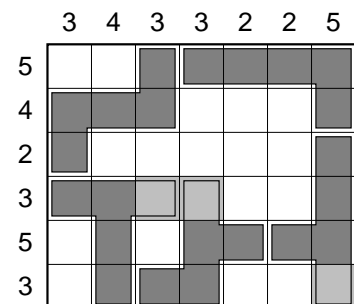
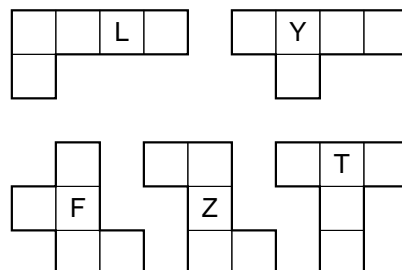
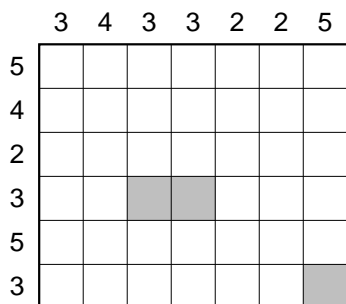

Answer key: Enter the letters assigned to the pentominoes in the order they are passed through along the path. Start with Z and move clockwise.

For the example, the answer key would be: ZLYFT

17 Crossword Wheel

40 Punkte

Place all given words into the diagram. In both rings, the words must be written clockwise; the final letter of each word must be the starting letter of the next. In the spokes, the words must be written from the outside to the center.

Example:

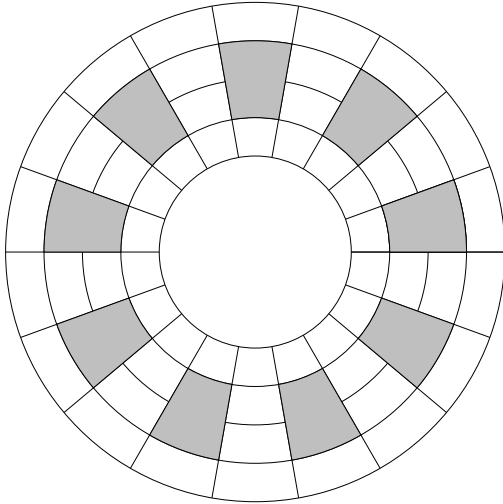

- ABER
- AQUA
- ATOM
- BLEI
- ELBA
- GAST
- INKA
- KRAN
- KUBA
- LAMM
- MARS
- OPUS
- PAKT
- QUAL
- RAGE
- REIS
- ROHR
- SPUK
- STEG
- TANZ
- ZIEL

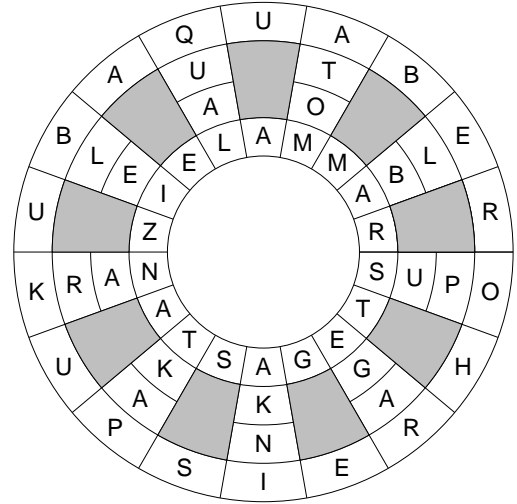

Answer key: Enter the letters from the inner ring clockwise, starting with an arbitrary letter.

For the example, one possible answer key would be: LAMMARSTEGASTANZIE

18 Symmetry

50 points

Divide the diagram along the grid lines into 13 parts. Each part must have rotational symmetry (which means, it must appear unchanged if rotated by 180°, including symbols and colors).

There are no two parts of same size and shape, ignoring rotations, reflections and symbols.

Example (6 parts):

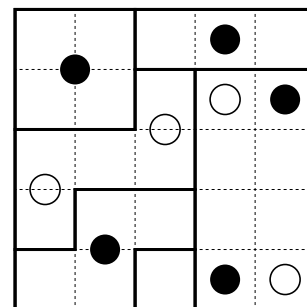
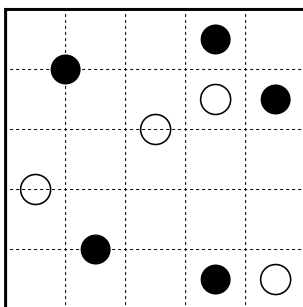

Answer key: Enter the area of all 13 parts, sorted according to size, in ascending order.

For the example, the answer key would be: 1, 3, 4, 4, 5, 8

19 Magic Arrows

50 points

Place the ten given pieces into the diagram without overlapping, such that each row (in all three possible directions) contains each symbol at most once. The pieces may not be placed on one of the symbols already given.

The pieces may be rotated (not reflected); however, their symbols will be rotated as well.

Example (three pieces only, square grid instead of hexagonal):

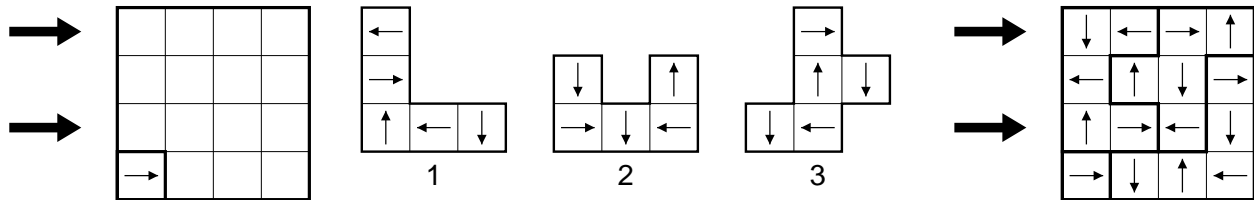

Answer key: The pieces have been assigned numbers from 0 to 9. For the marked rows, enter for each cell the number of the piece which is placed in that cell.

For the example, the answer key would be: 2233, 2231

20 Umbrellas

65 points

Place a number of umbrellas into the diagram, such that the falling water complies with the following rules:

- 1) The numbers above the diagram indicate, how many units of water fall into the diagram (along the grid lines); the numbers below the diagram indicate, how many units leave the diagram along the respective grid line.
- 2) As long as there is no umbrella, water will always drop down vertically.
- 3) Water that hits an umbrella left to the center will run to the left edge of that umbrella; water that hits an umbrella right to the center will run to the right edge. In both cases, it will drop down vertically after that.
- 4) For umbrellas with an even width, only an even number of water units may hit that umbrella in the center. Half of the water will run to the left edge, the other half to the right edge of that umbrella.

The umbrellas have various width and always height of one square; the numbers left of the diagram indicate which umbrella widths can be found in the respective row. If there are more than one umbrella in a row, the numbers are given in correct order. The umbrellas may touch each other, but not overlap (no square may be used by more than one umbrella).

Example:



Answer key: Enter the content of the marked rows from left to right. Use '0' for empty squares and '1' for squares that contain an umbrella.

For the example, the answer key would be: 011100, 110111